

Backward Curved Centrifugal Fan Ø 315 mm (12 1/2 inches)

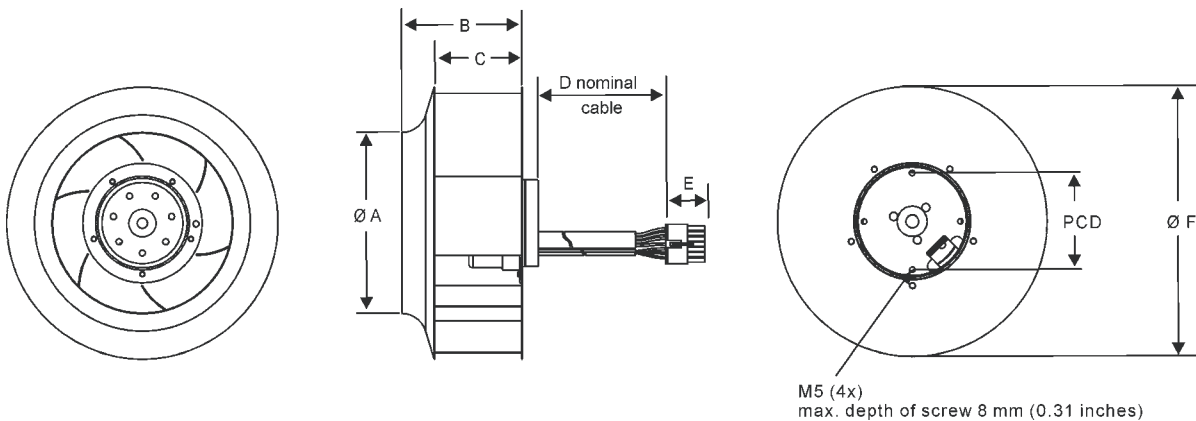

Fan Type	Motor	Air Flow m ³ /hr	Speed RPM	Input Power W	Operating from Pa
FB 315 E	DF 102 AA	2130	1950	210	0
FB 315 F	DF 102 BA	2370	2140	260	0

Product Dimensions:



Material: Galvanized Sheet Steel (Aluminium on request)

Dimensions	A	B	C	D*	E	F	PCD
mm	211	141	102	600	20	315	90
inches	8.31	5.55	4.02	23.62	0.79	12.4	3.54

Cable Tolerance: D* ±10 mm (±0.39 inches)

Air Flow Graph:

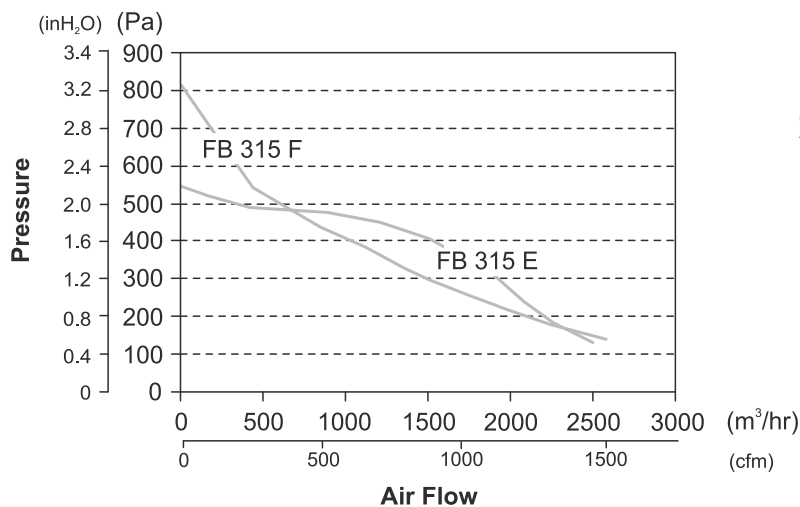

Lines drawn are recommended operating limits. By adjusting the motor speed, fans can operate at all pressure-flow points up to and including those drawn.