



Saving energy and cost with ECR  
2 speed evaporator fan motors



*Saving Generation for the Next Generation*

## Beverage Merchandisers

ECR01 2 speed motors can be used to reduce power consumption and thermal losses in beverage coolers and vending machines, by switching the fan to low speed when the compressor is not operating. This can be done by wiring the ECR motor's control wire (black wire) directly into the compressor circuit, so a system controller with fan control outputs is not needed.

Beverage merchandisers usually have an evaporator fan driven by a single speed shaded pole or ECM motor. In many coolers this fan runs continuously. Continuous operation is wasteful because:

- When the compressor is off, no heat is being extracted from the cooler, so no airflow is required. The power of the motor is therefore being wasted. Additionally, all of this power is being dissipated as heat inside the cooler, so more power must be used by the compressor to extract it.
- Un-needed airflow during the compressor-off period increases heat transfer through the cooler walls, resulting in faster warming, shorter compressor-off periods, and wasted power.

In coolers with premium system controllers, the evaporator fan runs continuously when the compressor is on, but only intermittently (enough to reduce stratification of warm and cold air) when the compressor is off. This reduces wasted power, but several problems remain.

- Some power is still wasted due to the fan running at full power during the “on” part of the intermittent cycle.
- Some stratification still occurs during the off period, increasing the temperature variation of product.
- A system controller capable of controlling the evaporator fan independently is required.
- At fan turn-on a pulse of warm air from the evaporator can be circulated around the cooler, causing false readings from the temperature sensor and reducing control effectiveness.

If a 2 speed ECR01 is used, the evaporator fan may be switched to low speed when the compressor is off. The advantages of this approach are:

- Air is circulated continuously, so stratification and false temperature readings are eliminated.

- Fan power consumption is proportional to fan speed cubed, so during compressor-off periods a fan running continuously at part speed uses less power than one running intermittently at full speed, and much less power than one running continuously at full speed.
- No system control connection is required. If a system controller is used, a low cost unit without a fan control output (such as Elstat EMS25) is suitable.

For best results the ECR01 motor should be connected so that the motor runs at full speed when the compressor is on, at part speed when the compressor is off, and stops when the door switch is open. Wiring diagrams to achieve this are shown in figures 1 and 2.

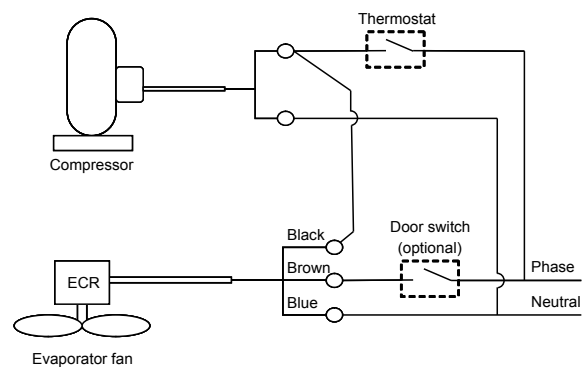

Figure 1: Example wiring diagram - ECR01 2-speed in beverage cooler without system controller

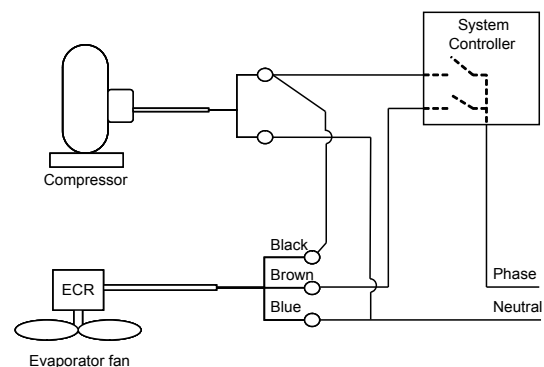

Figure 2: Example wiring diagram - ECR01 2-speed in beverage cooler with system controller  
System controller should be programmed for “fan off” when compressor is off

## Walk-in Coolers

ECR85 and ECR95 50W 2 speed motors can be used to reduce power consumption and thermal losses in walk-in coolers, by switching the fan to low speed when the evaporator is not in a cooling cycle. For single-compressor systems, this can be done by wiring the ECR motor's control wire (black wire) directly into the compressor circuit. For central compressor systems, it can be done by wiring the control wire either into the liquid line solenoid (if a mains-voltage solenoid is fitted) or into an evaporator fan controller such as those sold in the USA by Frigitek or Functional Devices.

In most walk-in chillers, the evaporator fans run continuously whether the evaporator is in a cooling cycle or not. Continuous operation is wasteful because:

- When the evaporator is not cooling, no heat is being extracted from the cooler, so no airflow is required. The power of the motor is therefore being wasted. Additionally, all of this power is being dissipated as heat inside the cooler, so more power must be used by the compressor to extract it.
- Un-needed airflow during the non-cooling period increases heat transfer through the cooler walls and air exchange through the doors, resulting in faster warming, shorter compressor-off periods, and wasted power.
- Un-needed airflow during the non-cooling period increases drying out of exposed perishable products.

If a 2 speed ECR85 or ECR95 is used, the evaporator fans may be switched to low speed when the evaporator is not in a cooling cycle. The fan will provide just enough airflow to prevent stratification without wasting power or drying product.

The ECR85 or ECR95 motor should be wired so that the blue and brown wires are permanently connected to phase and neutral, and the black wire is connected to phase when the evaporator is cooling, and disconnected or connected to neutral when the evaporator is not cooling. Typical wiring diagrams are shown in figures 3 and 4.

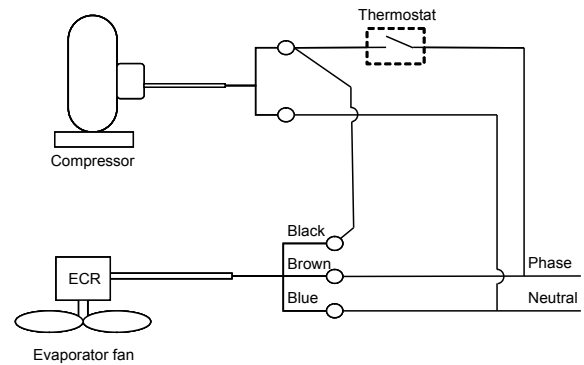

Figure 3: Example wiring diagram ECR85/95 2-speed in installation with dedicated compressor

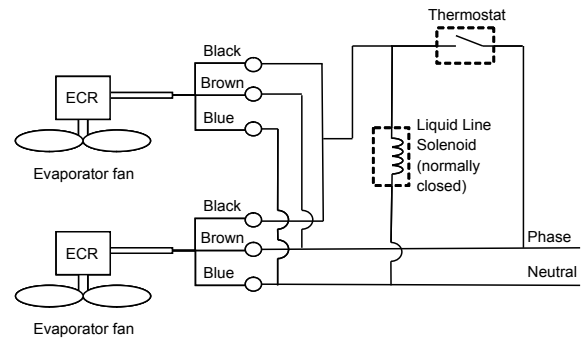

Figure 4: Example wiring diagram - ECR85/95 2-speed in installation with liquid line solenoid

## Closed-front supermarket and food service display cabinets

ECR01 2 speed motors can be used to reduce power consumption and thermal losses in display cabinets. In closed-door cabinets, this can be achieved by switching the fan to low speed when the evaporator is not in a cooling cycle. Fan speed can be controlled by wiring the ECR01's control wire (black wire) control wire either into the liquid line solenoid (if a mains-voltage solenoid is fitted) or into the fan motor output of the case controller.

In many closed door display cabinets, the evaporator fan runs continuously whether the evaporator is in a cooling cycle or not. Continuous operation is wasteful because:

- When the evaporator is not cooling, no heat is being extracted from the cabinet, so no airflow is required. The power of the motor is therefore being wasted. Additionally, all of this power is being dissipated as heat inside the cabinet, so more power must be used by the compressor to extract it.
- Un-needed airflow during the non-cooling period increases heat transfer through the cabinet walls, resulting in faster warming, shorter compressor-off periods, and wasted power.
- Un-needed airflow during the non-cooling period increases drying out of exposed perishable products.

In other cabinets, the evaporator fan is switched off when the evaporator is not in a cooling cycle. This saves power, but leads to stratification of the air inside the cabinet, allowing the temperature of products in the case to vary.

By using the ECR01's 2 speed capability to reduce fan speed without turning it off, power can be saved while maintaining good temperature control. The ECR01 is set up to run at reduced speed when not cooling, providing just enough airflow to prevent stratification.

The ECR01 motor should be wired so that the blue and brown wires are permanently connected to phase and neutral, and the black wire is connected to phase when the evaporator is cooling, and disconnected or connected to neutral when the evaporator is not cooling. Typical wiring diagrams are shown in figures 5 and 6.

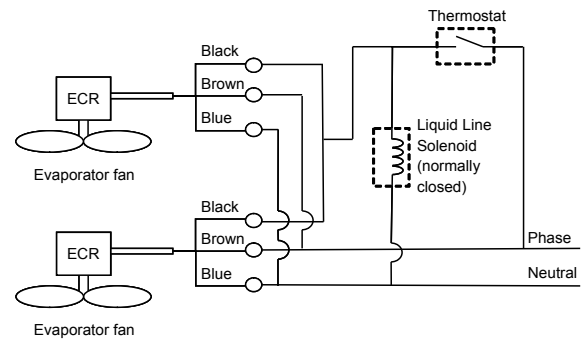

Figure 5: Example wiring diagram – ECR01 2-speed in display case without case controller

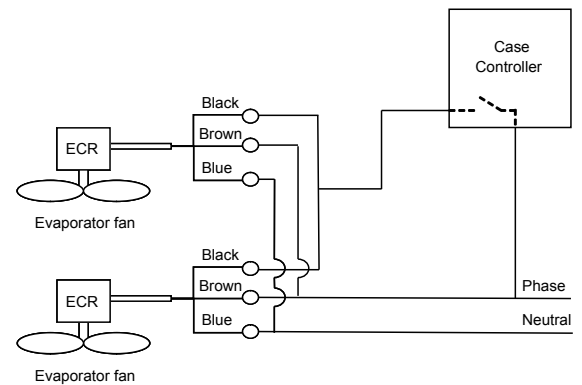

Figure 6: Example wiring diagram – ECR01 2-speed in display case with case controller  
Case controller should be programmed for “fan off” when not in cooling cycle

## Open-front supermarket and food service display cabinets

ECR01 2 speed motors can be used to reduce power consumption and thermal losses in display cabinets. In open-front cabinets this can be achieved by switching the fan to low speed when in night mode. Fan speed can be controlled by wiring the ECR01's control wire (black wire) control wire either into a night mode switch, or into the fan motor output of the case controller.

In many open-front cabinets, a "night mode" option is available. This may involve lowering a night curtain and switching off lighting. However, the evaporator fans typically continue to run while in night mode. This wastes power, as the airflow needed to maintain temperature when the night curtain is fitted is much lower than when it is not. Excessive airflow:

- Wastes the motor power needed to generate the airflow. Additionally, this power is dissipated as heat inside the cabinet, so more power must be used by the compressor to extract it.
- Increases heat transfer through the cabinet walls, resulting in faster warming, shorter compressor-off periods, and wasted power.
- Increases drying out of exposed perishable products.

By using the ECR01's 2 speed capability to reduce fan speed without turning it off, power can be saved while in night mode. The ECR01 is set up to run at reduced speed while in night mode, providing the minimum airflow necessary to maintain temperature.

The ECR01 motor should be wired so that the blue and brown wires are permanently connected to phase and neutral, and the black wire is connected to phase when the cabinet is in day mode, and disconnected or connected to neutral when cabinet is in night mode. Typical wiring diagrams are shown in figures 7 and 8.

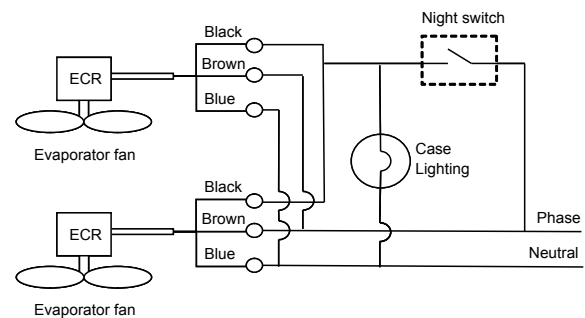

Figure 7: Example wiring diagram – ECR01 2-speed in open front case without case controller  
Lighting should be connected to same phase as motors in multi-phase cases

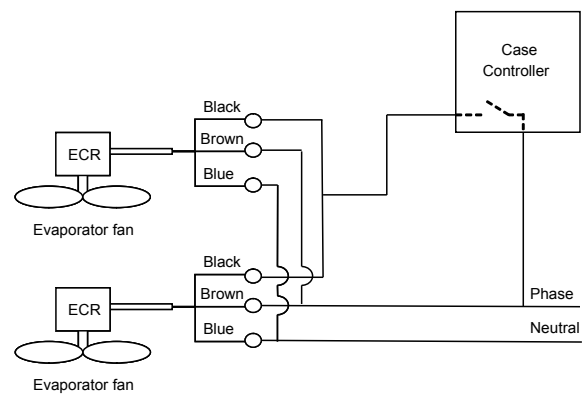

Figure 8: Example wiring diagram – ECR01 2-speed in open front case with case controller  
Case controller should be programmed for "fan off" in night mode



*Saving Generation for the Next Generation*

## USA

Wellington Drive Technologies US, Inc.  
1407 Barclay Blvd  
Buffalo Grove, IL 60089  
USA  
Phone: +1 (224) 588-8712  
Toll Free: +1 (888) 786-4153  
Email: [sales@wdtl.com](mailto:sales@wdtl.com)

## MEXICO

Wellington Drive Technologies Mexico  
PO Box 57  
San Juan del Rio  
Querétaro  
Mexico 76800  
Phone: +52 427 112 9101  
Email: [sales@wdtl.com](mailto:sales@wdtl.com)

## NEW ZEALAND

Wellington Drive Technologies Ltd  
16-22 Omega Street, North Harbour  
Auckland 0632  
New Zealand  
Phone: +64 (0) 9 414 6590  
Fax: +64 (0) 9 414 6591  
Email: [info@wdtl.com](mailto:info@wdtl.com)

## ITALY

Wellington Italia Srl  
Via Torino, 2  
20123, Milan  
Italy  
Phone: +39 02 7254 6746  
Fax: +39 02 7254 6400  
Email: [sales@wdtl.com](mailto:sales@wdtl.com)

## TURKEY

Wellington Motor Teknolojileri San Tic Ltd Sti  
Bostanci Yolu Cad Keyap Sitesi, No:105  
Yukari Dudullu, Umraniye 34775 Istanbul  
Turkey  
Phone: +90 (0) 216 420 1202  
Fax: +90 (0) 216 420 1205  
Email: [sales@wdtl.com](mailto:sales@wdtl.com)

## SINGAPORE

Wellington Drive Technologies Pte Ltd  
39 Tampines Street 92  
#4-00  
Singapore 528883  
Phone: +65 6373 7200  
Fax: +65 6373 7201  
Email: [sales@wdtl.com](mailto:sales@wdtl.com)

©2011 Wellington Drive Technologies Limited. Trademarks are (as applicable) 'TM' and ® of Wellington Drive Technologies Limited. While all information in this document is believed by Wellington Drive Technologies Limited to be accurate and reliable, Wellington Drive Technologies Limited and its subsidiaries and affiliates and their directors, officers and employees are not responsible for any errors or omissions of any kind whatsoever, and to the maximum extent permitted at law, have no liability in tort, contract, or otherwise to any user and/or any third party.



WT7502 March 2011